

MODEL: 8090-811-250

SPECIFICATIONS:

MODEL NUMBER: 8090-811-250

PUMP DESIGN: Positive Displacement 3 Chamber Diaphragm Pump

CAM: 2.0 Degree

MOTOR: Permanent Magnet, P/N 11-160-00, Thermally Protected

VOLTAGE: 230 VAC Nominal

PRESSURE SWITCH: None

LIQUID TEMPERATURE: 180 Degrees Fahrenheit (82 Degrees Centigrade) Max.

PRIME: Self-Priming Up To 7.0 Ft. Vertical,
Max. Inlet Pressure 30 PSI (2.1 Bar)

PORTS: 3/8"-18 NPT Female

MATERIAL OF CONSTRUCTION:

PLASTICS- Nylon

VALVES- Viton

DIAPHRAGM- Santoprene

FASTENERS- Zinc Plated Steel

NET WEIGHT: 3.85 Lbs (1.75 Kg)

DUTY CYCLE: Intermittent (See Temperature Rise Chart)

TYPICAL APPLICATIONS Soil Extraction

BYPASS: 60 PSI Max.

APPROVALS: VDE Approved

DIMENSIONS:

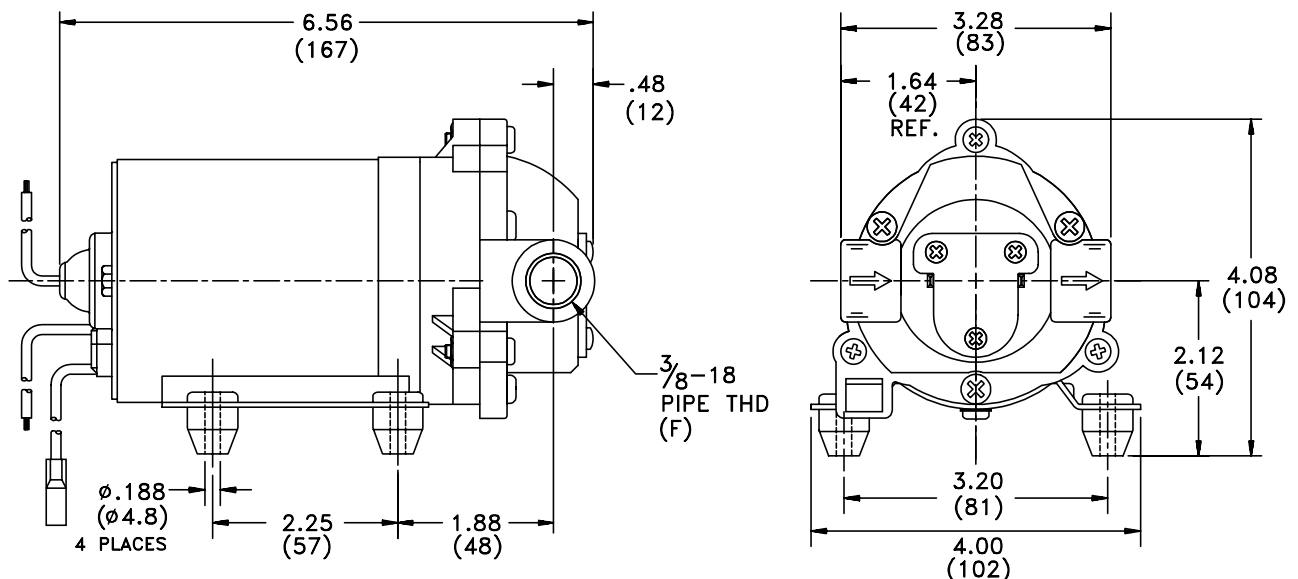

TEMPERATURE RISE

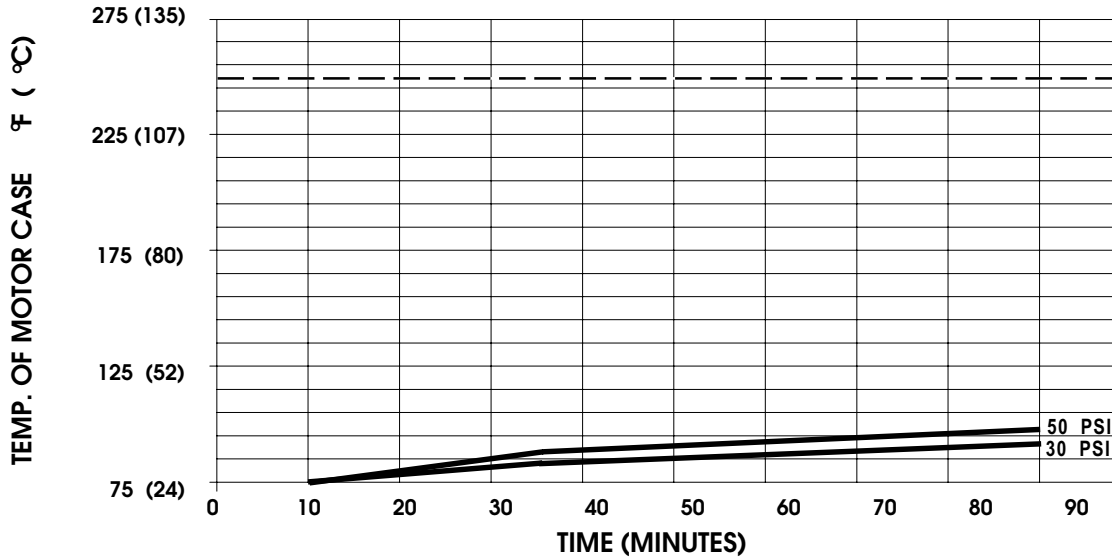

THIS GRAPH IS FOR USE AS A DESIGN GUIDE. IT IS BASED ON RUNNING CONTINUOUSLY WITH AN AMBIENT TEMPERATURE OF 70° F IN STILL AIR. THE THERMAL BREAKER WILL OPEN WHEN THE CASE TEMPERATURE REACHES 250° F.

[- - - - - TRIP POINT OF THERMAL PROTECTOR]

TYPICAL PERFORMANCE

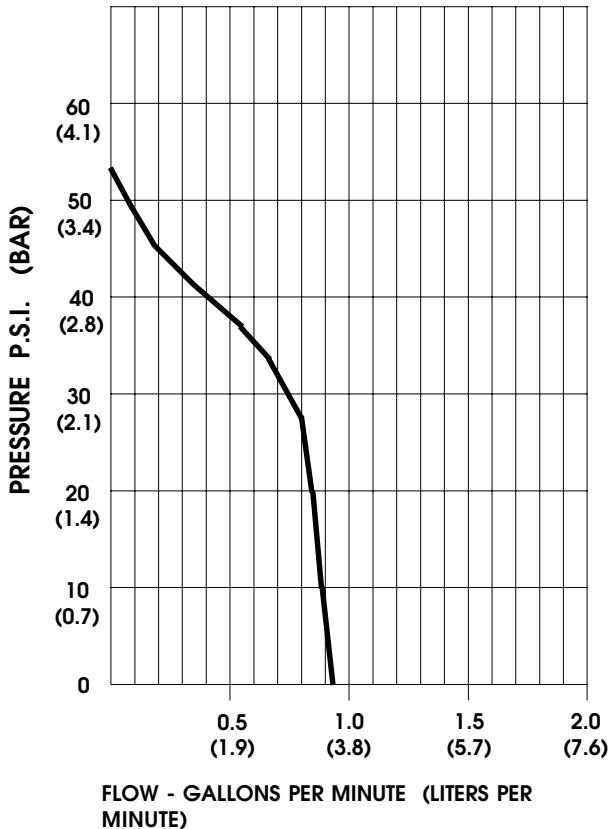

PRESSURE (PSI)	FLOW (GPM/LIT)	RPM MIN/MAX	CURRENT (AMPS)	VOLTAGE (VOLTS)
OPEN	0.93/3.5	2250/2405	0.11	230VAC
10	0.86/3.2	2170/2325	0.12	"
20	0.83/3.1	2105/2235	0.14	"
30	0.71/2.7	2015/2160	0.16	"
40	0.28/1.1	1960/2075	0.17	"

-SPECIFICATIONS SUBJECT TO CHANGE WITHOUT NOTICE.
 -ALL DATA BASED ON TESTING WITH WATER AT AMBIENT TEMPERATURE.